

Operation and Maintenance, Spare Parts

GAS PRESSURE REGULATOR RMG 503

503.20

DN 25/50 to DN 150/300

Edition 09/2006



Contents	Page
1. General information	3
1.1 Safety information	3
2. Gas pressure regulator	4
2.1 Specific operating instructions	4
2.1.1 Starting up	4
2.1.2 Closing down	4
2.2 Specific maintenance instructions	4
2.2.1 Tightening torques	4
2.2.2 Lubricants	4
2.3. Spare parts	
2.3.1 Spare parts – drawings	5, 6
2.3.2 Spare parts	7
3. Integrated SAV system RMG 711	
3.1 Specific operating instructions	9
3.2 Specific maintenance instructions	9
3.2.1 Switch device	9
3.2.2 Actuator	10
3.2.3 Tightening torques	10
3.2.4 Lubricants	10
3.3 Spare parts	
3.3.1 Spare parts – drawings	11, 12, 13
3.3.2 Spare parts	14, 15
3.3.3 Spare parts drawing – accessories	16
3.3.4 List of spare parts – accessories	17
4. Parts for maintenance purposes	18

1. General information

All persons involved with the assembly, operation and/or maintenance of the RMG 503 gas pressure regulator must read and understand all of the following documents:

- **Technical product information 503.00** - it contains the technical data and dimensions of the equipment as well as instructions concerning set-up and mode of operation.
- **General operating manual for gas pressure regulators and safety devices** - this RMG document contains information on assembly and operation as well as general information on troubleshooting.
- **Operating and maintenance instructions / spare parts 503.20** - this document contains more detailed information on assembly and operation of the RMG 503 gas pressure regulator.
- **The various components and units** are described in separate booklets "Operating and Maintenance Instructions, spare parts":

Pilot	RMG 630/640	630.20
Filter	RMG 905	905.20
Control unit	K 10a / K 11a	672.20
Control unit	K 16 / K 17 / K 18	670.20
Probe valve	RMG 910a	910.20
Probe valve	RMG 913a	913.20

There are **national** laws and regulations for all sorts of jobs on gas pressure regulators, from planning to maintenance. Be sure to comply. (In Germany, for instance, DVGW work sheets G 600, G 459/II, G 491 and G 495.)

Inspection and maintenance intervals depend mostly on operating conditions and the nature and properties of the gas. There are no general rules or recommendations for intervals. For Germany, we recommend to consider maintenance intervals as stated in DVGW work sheet G 495 in a first instance. However, in the mid-term, intervals must be adapted to the requirements of each specific equipment.

During maintenance, components must be cleaned and then checked thoroughly. This is necessary even if there have not been any unusual observations during operation and/or functional testing. Checks must focus, in particular, on diaphragms and seals and all movable parts and their respective bearings. Any and all defective parts must be replaced with new ones. The same applies to O rings removed during disassembly.

Item numbers mentioned in the specific operating and maintenance instructions correspond with the numbers in the spare parts lists and drawings.

Some parts in the lists and drawings are marked with a letter "W". We recommend you always have a reserve of those parts in stock for maintenance purposes. Those spare parts are put together in another separate list at the end of the spare parts list.

1.1 Safety information

In this manual, safety information is highlighted by means of the following titles and eye catchers:

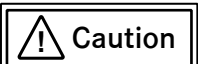
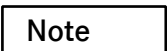
Eye catchers	used for:
	danger to life and limb
	danger of damage to property and/or the environment
	important additional information

2. Gas pressure regulator

2.1 Specific operating instructions

2.1.1 Starting up

- Close the shut-off device at the outlet.
- Turn the setpoint adjusting screw ccw to completely release the setpoint springs of pilots RMG 630/640 of the control stage and auxiliary pressure stage (only pilot RMG 630).

Note

Open the start-up valve.

The purpose of the start-up valve is to safely equalise the inlet pressure acting on the restrictor diaphragm.

Caution

Apply the inlet pressure **slowly**.

Note

- Be absolutely sure to close the start-up valve again.
- Set the setpoint of the auxiliary pressure stage of pilot RMG 630 to approx. 10 bar above pa. Turn the adjusting screw cw to adjust the outlet pressure in small steps until you reach the desired level. The auxiliary pressure of RMG 630 will increase automatically in the process.

2.1.2. Closing down

- Turn the setpoint adjusting screw of the control stage ccw.
- Slowly close the shut-off device at the outlet.

2.2 Specific maintenance instructions

This gas pressure regulator has been designed for ease of maintenance. Maintenance is, therefore, limited more or less to checking the restrictor diaphragm. Check for wear and expansion due to moisture. Replace, when necessary.

Danger

Before disassembly, chambers filled with gas must be evacuated.

- It must be possible to insert restrictor diaphragm (306) into the housing without putting it under tension.
- The plastic foam rings (314 and 319) DN 80/150 and up must be replaced during every maintenance job.
- Only DN 25/50 and DN50/100 (up to type no. 030733900), DN80/150 and DN100/200 (up to type no. 041137509) On the type with noise reduction with pair or relief plates (323): Be sure to observe proper fitting position.

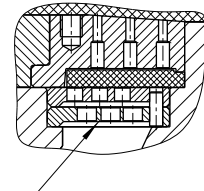

Groove of relief plates.
Must be towards the bottom.

2.2.1 Tightening torques M_A in Nm

Screws and bolts Item No.	Nominal width DN				
	25/50	50/100	80/150	100/200	150/300
318	160	160	240	240	560

2.2.2 Lubricants

Components	Lubricants	RMG part no.
All O rings and diaphragm support	Silicone grease	27081 (tube 0.1 kg)
All fastening screws and screwed pipe connections	Assembly grease	28267

2.3.1 Spare parts – drawings

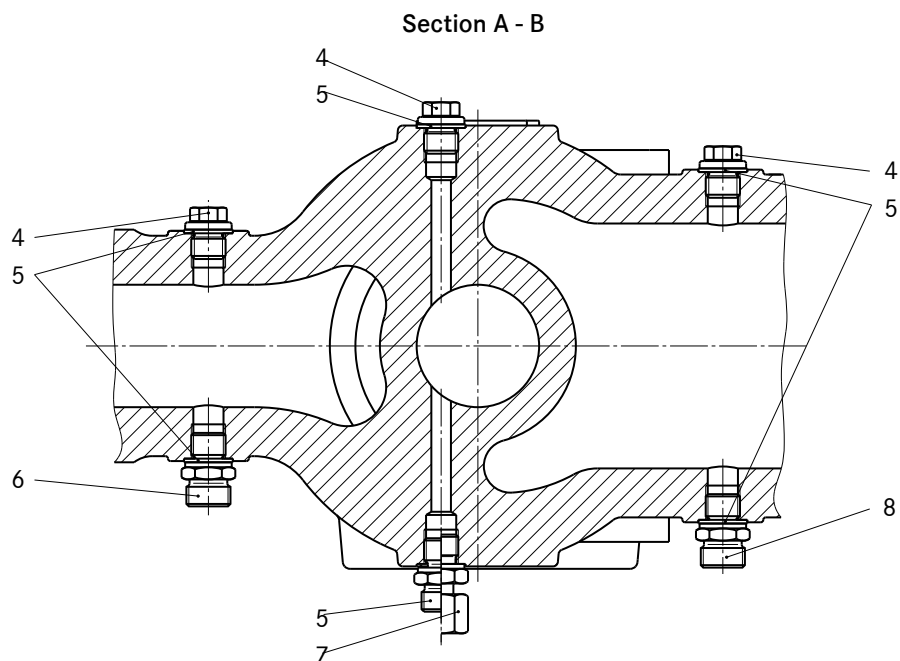
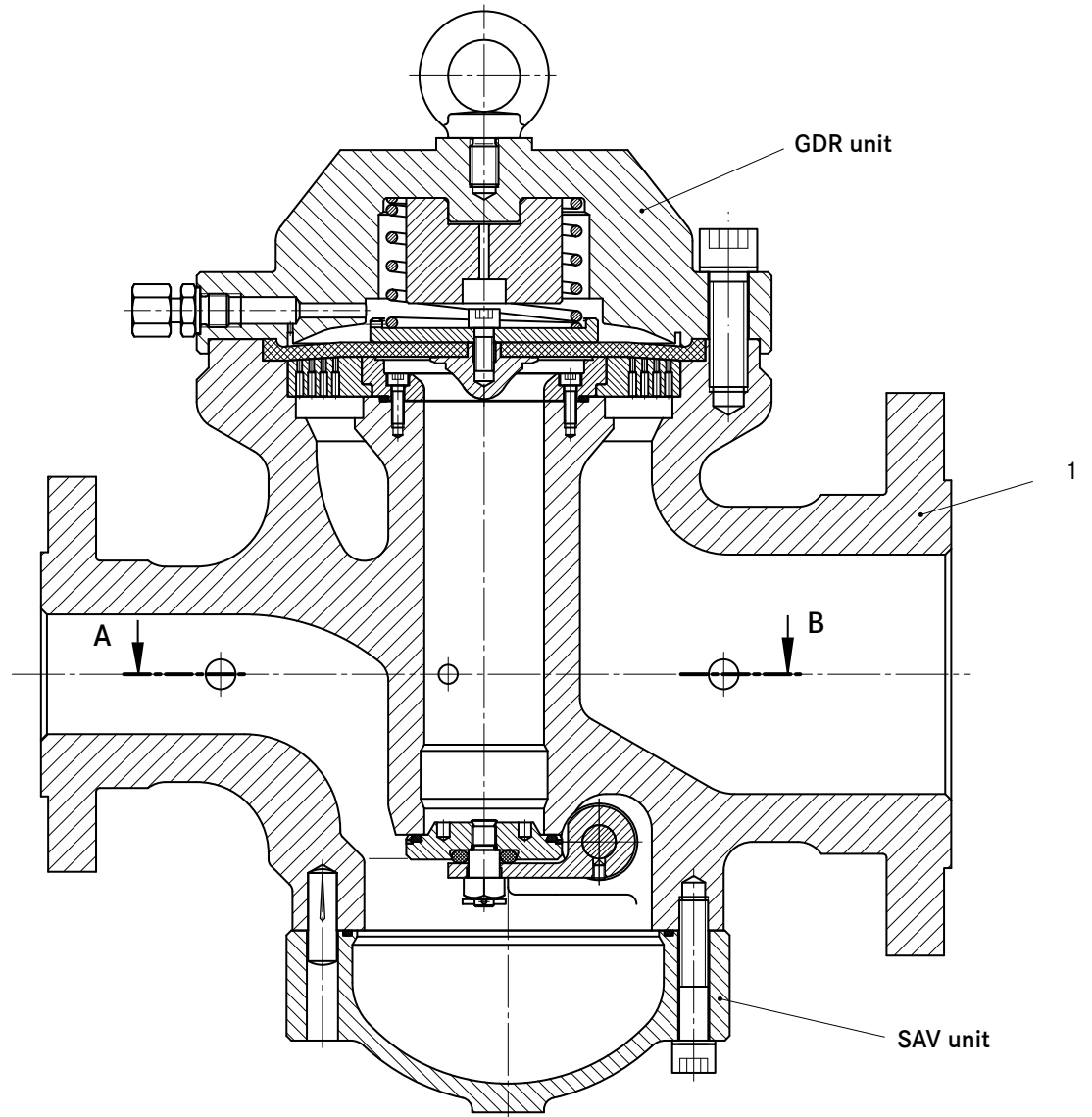

DN 25/50 and DN 50/100

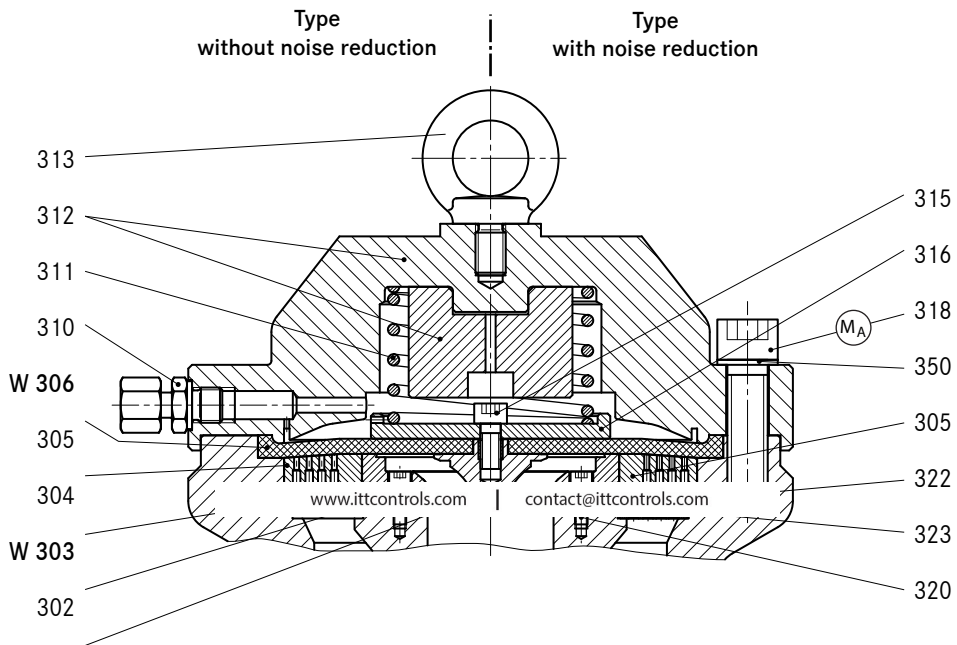

DN 80/150 thru DN 150/300

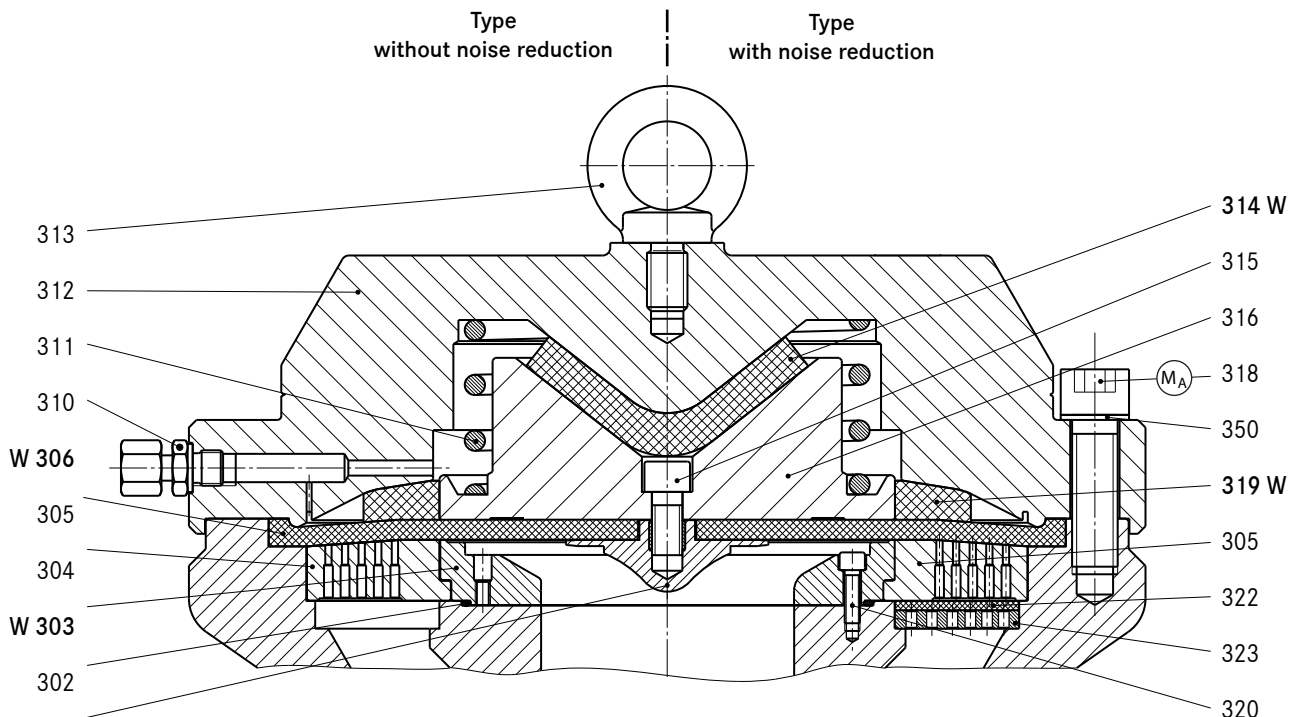

M_A Be sure to comply with tightening torques in table on page 4.

W Parts should be held in stock for maintenance purposes.

2.3.2. List of spare parts

Item No.	Denomination	No.	W	Material	Part no.				
					DN 25/50	DN 50/100	DN 80/150	DN 100/200	DN 150/300
1	Housing – revision “-”:								
1	PN 40	1		GS	10024470	10024520			
1	PN 40 / ANSI 600 RF	1		GS	10024477	10024527			
1	ANSI 300 RF	1		GS	10024473	10024523			
1	ANSI 300 RF / ANSI 600 RF	1		GS	10024478	10024528			
1	ANSI 300 RJ	1		GS	10024474	10024524			
1	ANSI 600 RF	1		GS	10024475	10024525			
1	ANSI 600 RJ	1		GS	10024476	10024526			
1	Housing – assembly situation “a”:								
1	PN 40	1		GS			10027670	10027720	10030440
1	PN 40 / ANSI 600 RF	1		GS			10027677	10027727	10030445
1	ANSI 300 RF	1		GS			10027673	10027723	10030441
1	ANSI 300 RF / ANSI 600 RF	1		GS			10027678	10027728	10030446
1	ANSI 300 RJ	1		GS			10027674	10027724	10030442
1	ANSI 600 RF	1		GS			10027675	10027725	10030443
1	ANSI 600 RJ	1		GS			10027676	10027726	10030444
4	Sealing cap	3		St	26175	26175	26175	26175	26175
5	Sealing ring	6		LM	18842	18842			
5	Sealing ring	5		LM			18842	18842	18842
6	Connection pipe	1		St	30074	30074	30111	30111	30111
7	Connection pipe	1		St	30111	30111	30023	30023	30023
8	Connection pipe	1		St	30074	30074	30074	30074	30074

W Parts should be held in stock for maintenance purposes.

German abbreviations stand for the following materials:

St ... steel

NSt ... stainless steel

FSt ... spring steel

NFSt ... stainless spring steel

Bz ... bronze

Cu ... copper

LM ... light metal / alloy

Ms ... brass

GS ... cast steel

GGG ... spheroidal graphite cast iron

GBz ... cast bronze

GLM ... cast light metal

GMs ... cast brass

GZn ... cast zinc

AlBz ... aluminium bronze

K ... synthetic materials

KG ... gummy synthetic materials

SSt ... foamed materials

Item No.	Denomination	No.	W	Material	Part no.				
					DN 25/50	DN 50/100	DN 80/150	DN 100/200	DN 150/300
302	Flow cone	1		LM	10011137	10011137	10011237	10011237	10023696
303	O ring	1	W	KG	20508	20508	21184	21184	20541
304	Insert	1		St	10023551	10023551	10023631	10023631	10023687
305	Flow restrictor	1		LM	10023552	10023552	10023629	10023629	10023684
306	Diaphragm	1	W	KG	10011306	10011306	10011307	10011307	10023697
310	Connection pipe	1		St	30023	30023	30023	30023	30023
311	Pressure spring	1		NFSt	10011149	10011149	10011249	10011249	10023692
312	Diaphragm cap	1		St	10021590	10021620	10021653	10021685	10023686
313	Eye bolt	1		St	10021	10021	10003	10003	10047
314	Plastic foam disc	1	W	SSt			10023593	10023633	10023689
315	Cheese head screw	1		St	8176	8176	10393	10393	10270
316	Diaphragm disk	1		LM	10011138	10011138	10011238	10011238	10023695
318	Cheese head screw	10		St	10555	10555			
318	Cheese head screw	24		St			10601	10601	
318	Cheese head screw	30		St					10589
319	Plastic foam ring	1	W	SSt			10023592	10023632	1023688
320	Cheese head screw	4		St	10030354	10030354	10030356	10030356	10030392
322	Metal foam ring	1		Ni	10023556	10023556	10023635	10023635	10023691
323	Relief plate	1		LM	10023513	10023513	10023594	10023594	10023690
350	Lock washer	10		FSt	14116	14116			
350	Lock washer	24		FSt			14139	14139	
350	Lock washer	30		FSt					14129

3. Integrated SAV system RMG 711

3.1 Specific operating instructions

Opening the safety shut-off valve (SAV in German)

- In order to open the SAV device, insert handle bar (712) into the bore hole of disc (734) and turn.

Note

On actuators K 10a and K 11a, the SAV device can be opened only, if the actuator has been engaged before.

- Engage actuators K 10a and K 11a by pulling on the switching rod.
Proceed as follows: Screw the sealing cap onto the switching rod, but the other way round (see 672.20).

Note

Actuators K 10a and K 11a are equipped with an underpressure shut-off.
They can be engaged only, if the pressure at the measuring point corresponds to the operating pressure.

Actuation tests on actuators K 10a and K 11a



Actuation tests may be carried out only, if actuators K 10a and K 11a are properly installed on switch housing (710). Otherwise, there is a danger of mechanical damage.

3.2 Specific maintenance instructions

3.2.1 Switch device

- Before you can dismantle switch bearing (707), you must screw off thrust piece (768) from switch housing (710).
- When assembling the switch bearing, take care of the following:
 - One of the angular twin stops of the switch bearing must point towards thrust piece (768).
(see 3.3.1 SAV system section A-A)
 - Slide ring (721) must be BELOW the switch bearing.

3.2.2 Actuator

Valve cap (753)

- For visual inspection of valve-clack O ring (754): Remove cap (747) and open (engage) the SAV. When you insert a new, well greased O ring (774) into the groove of valve clack (753), press it down gently into the groove at three or four evenly distanced points along the circumference. Only then should you press it down completely. When you take the valve clack from valve clack lever (750), first screw down lock nut (752) using the proper torque, then secure it using cotter pin (773).

Closing springs (731)

- Spring housing (733) contains two support grooves that take up the closing springs. The grooves are needed to take up the springs and provide for the different versions of the device with the "tending side left" or "tending side right".
- Installation: First insert the closing springs into spring housing (733). Make sure you position the springs exactly as shown in figs. 1 and 2.
- The closing springs are properly tensioned when all four fastening screws (732) can be installed inside the housing (about half turn of spring housing). The valve clacks must be closed during the procedure.

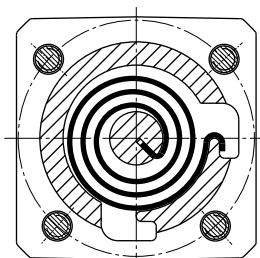

Fig. 1 Fitting position of closing spring with "tending side right".

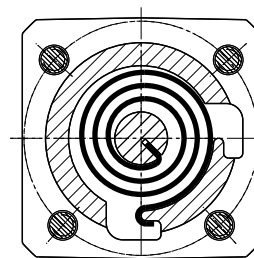

Fig. 2 Fitting position of closing spring with "tending side left".

3.2.3 Tightening torques MA

DN	Tightening torques MA in Nm				
	Screws & bolts – item #				
	708	732	745	752	800
25/50	8	8	40	8	-
50/100	8	8	75	12	-
80/150	20	20	160	40	10
100/200	20	20	160	40	10
150/300	40	40	350	80	10

3.2.4 Lubricants

Components	Lubricants	RMG part no.
Thread of manual release (767)	Assembly paste	27091
All O rings, slip guides, slip faces and switching elements	Silicone grease	27081 (tube 0.1 kg)
All fastening screws and screwed pipe connections	Assembly grease	28267

3.3.1. Spare parts – drawings

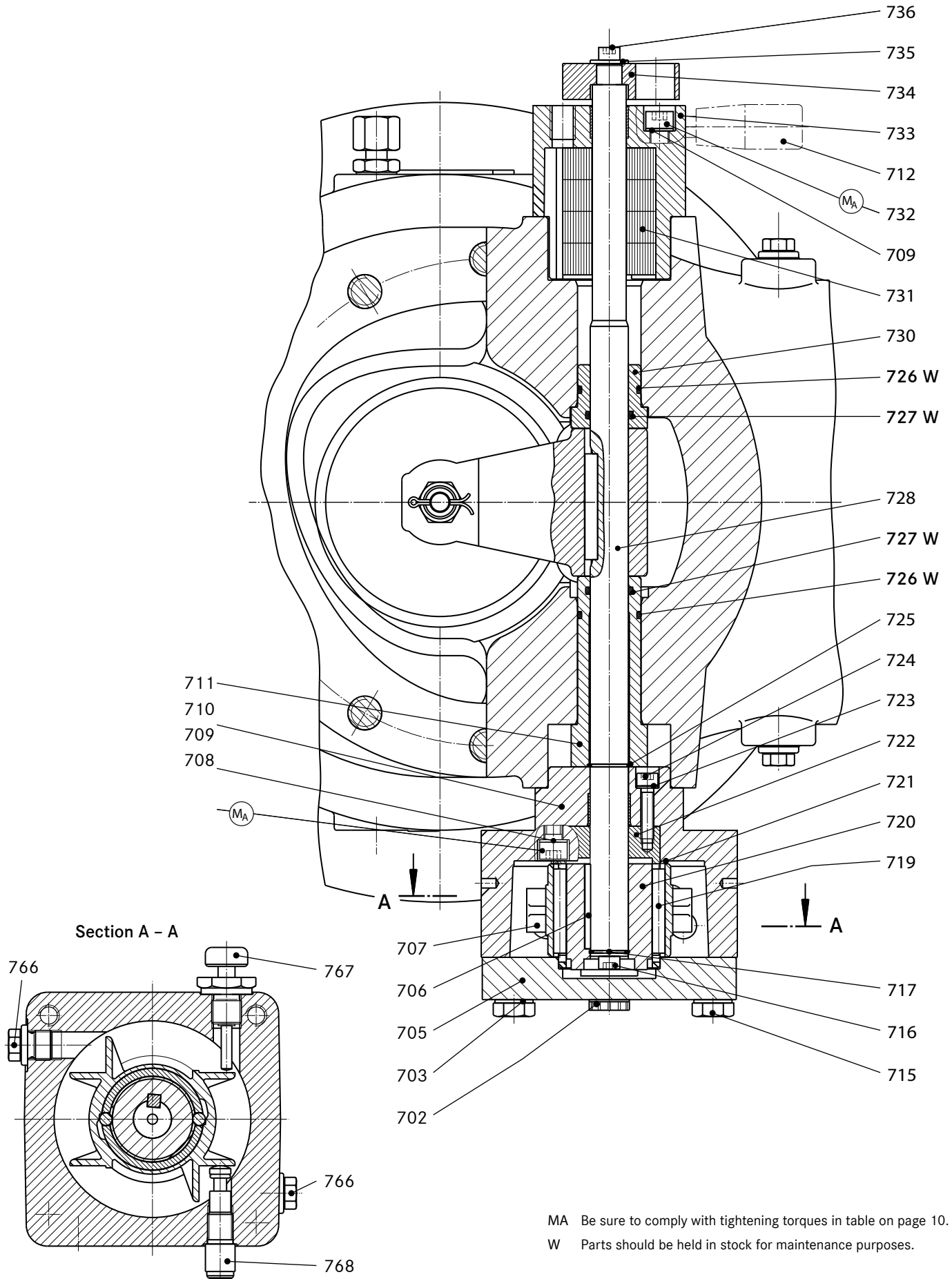

SAV unit DN25/50

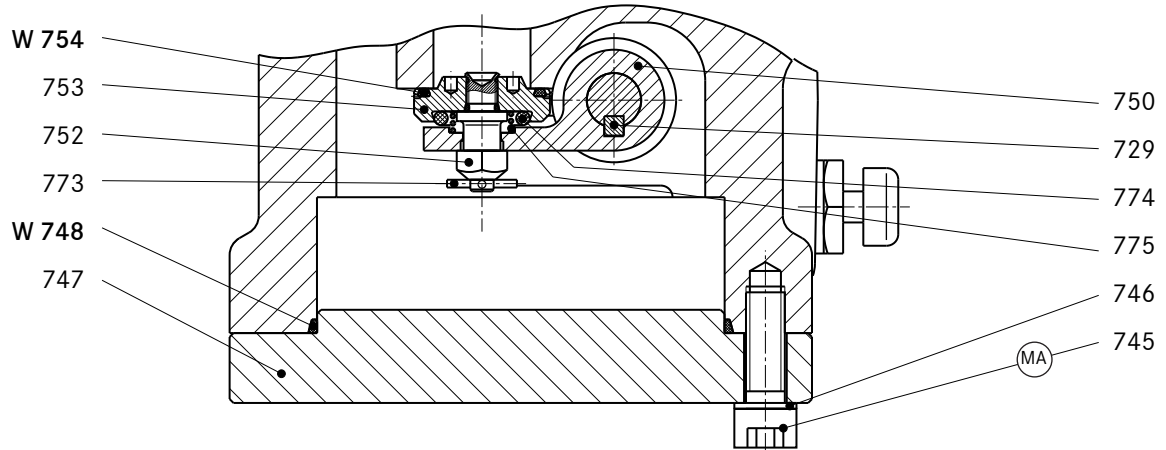

SAV unit DN50/100

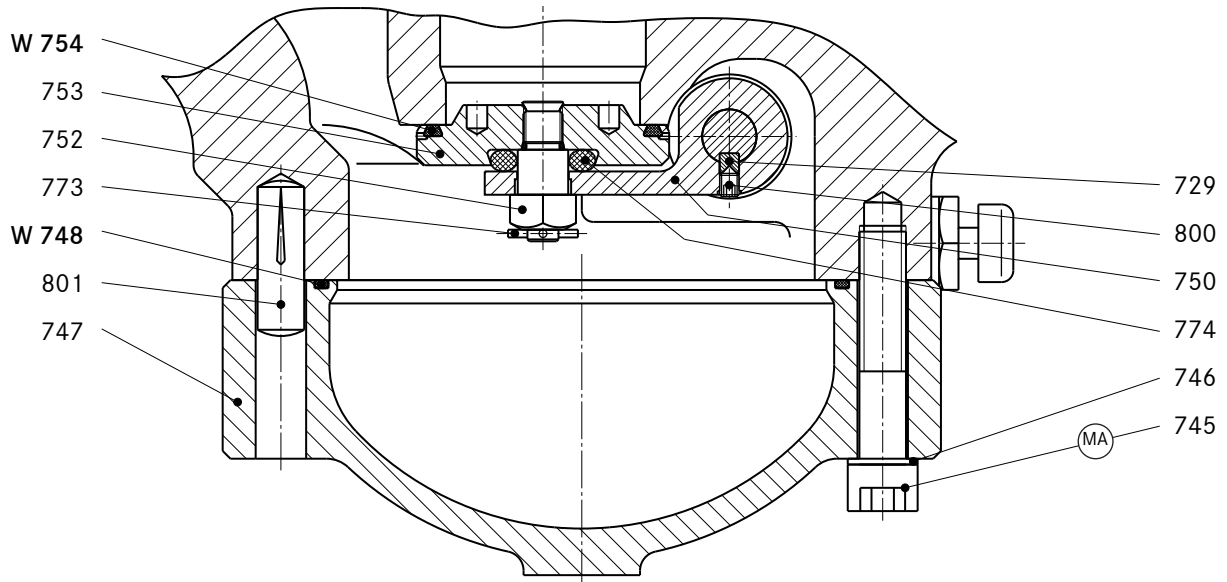

SAV unit
DN80/150 thru DN 150/300

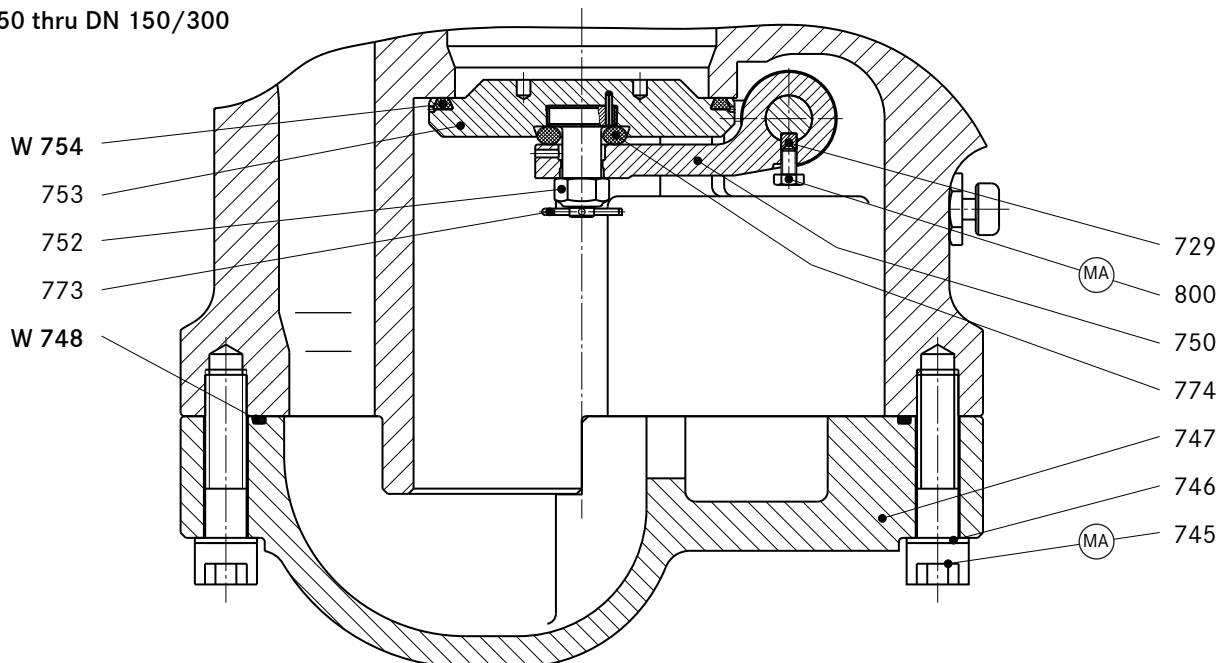

M_A Be sure to comply with tightening torques in table on page 4.

W Parts should be held in stock for maintenance purposes.

DN 25/50 and DN 50/100
with push button valve RMG 913a

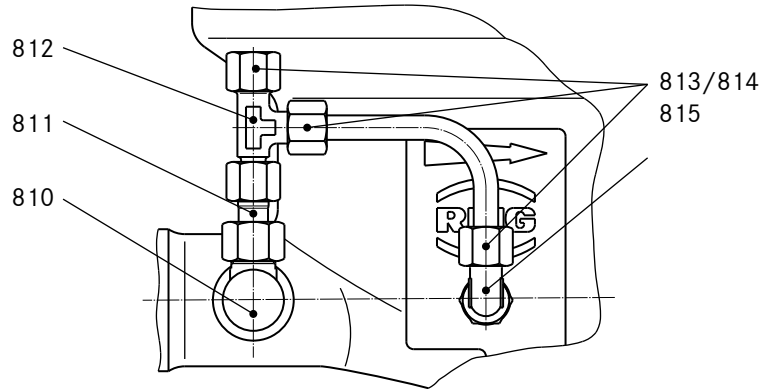

DN 80/150 thru DN 150/300
with push button valve RMG 910a

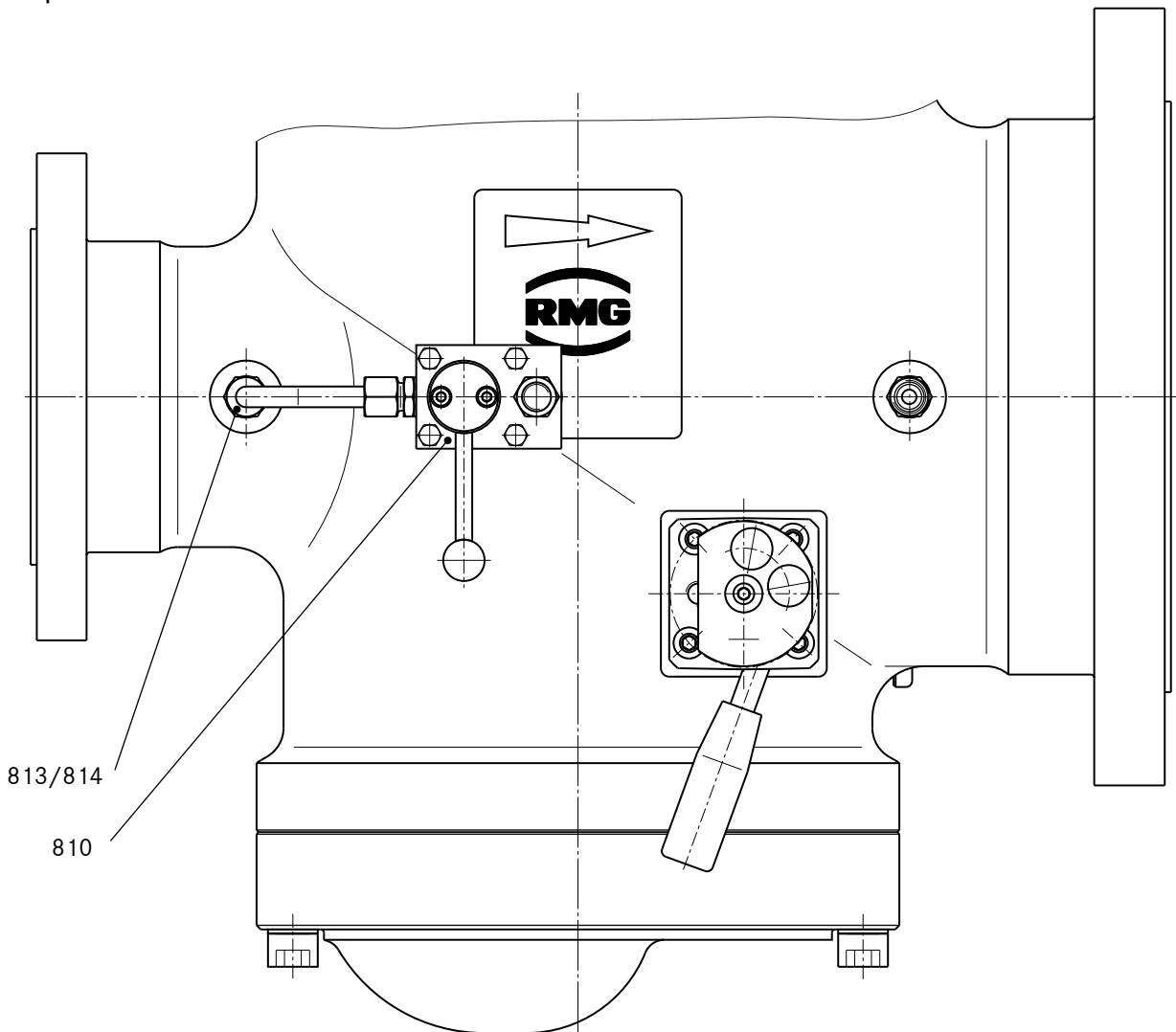

Item No.	Denomination	No.	W	Material	Part no.				
					DN 25/50	DN 50/100	DN 80/150	DN 100/200	DN 150/300
702	Plug	1		K	26550	26550	26550	26550	26550
703	Washer	4		St	8281	8281	14106	14106	8276
705	Switch housing cover	1		LM	10022323	10022323	10022423	10022423	10022473
706	Feather key	1		St	26255	26255	26240	26240	26264
707	Switch bearing	1		NSt	10022327	10022327	10024632	10024632	10022477
708	Cheese head screw	4		St	10120	10120	10379	10379	10441
709	Lock washer	8		FSt	14111	14111	14112	14112	14113
710	Switch housing, complete	1		GLM/K	10022326	10022326	10022426	10022426	10022476
711	Bearing bush	1		Ms	10022318	10022318	10027688	10027688	10030450
712	Handle bar, complete	1		NSt/K/KG	10024536	10024536	10024636	10024636	10022489
715	Hex screw	4		St	10083	10083	3873	3873	10611
716	Cheese head screw	1		St	8177	8177	8177	8177	8177
717	Washer	1		LM	10001186	10001186	10001386	10001386	10001486
719	Needle roller	2		St	27646	27646	27301	27301	27301
720	Lock bushing, complete	1		NSt/SF	10022332	10022332	10022432	10022432	10022482
721	Slide ring	1		KT	21140	21140	21112	21112	21191
722	Guide bush	1		NSt	10022330	10022330	10022430	10022430	10022480
723	Lock washer	3		FSt	14118	14118	14111	14111	14112
724	Cheese head screw	3		St	10561	10561	10150	10150	10098
725	Snap ring	1		FSt	19110	19110	19112	19112	19113
726	O ring	2	W	KG	20227	20227	20235	20235	20336
727	O ring	2	W	KG	21142	21142	20607	20607	20600
728	Valve cap shaft	1		NSt	10022317	10022317	10027687	10027687	10030449
729	Feather key	1		St	26256	10030246	10024646	10024646	10030456
730	Bearing bush	1		Ms	10022319	10022319	10022369	10022369	10022469
731	Spiral band spring	3		NSt	10022336	10022336			
731	Spiral band spring	4		NSt			10022436	10022436	10022486
732	Cheese head screw	4		St	10549	10549	10428	10428	10610
733	Spring housing, complete	1		GLM/K	10024535	10024535	10024635	10024635	10022485
734	Disc, complete	1		LM/St	10024540	10024540	10024640	10024640	10030455
735	Washer	1		St	14082	14082	14137	14137	10001486
736	Cheese head screw	1		St	10618	10618	8177	8177	8177
745	Cheese head screw	10		St	10400				
745	Cheese head screw	12		St		10625			
745	Cheese head screw	18		St			10669	10669	
745	Cheese head screw	24		St					100400
746	Lock washer	10		FSt	14113				
746	Lock washer	12		FSt		14114			
746	Lock washer	18		FSt			14116	14116	
746	Lock washer	24		FSt					14124
747	Cap	1		St	10022311	10024541	10027681	10027681	10030438
748	O ring	1	W	KG	20247	20427	21361	21361	21108

Item No.	Denomination	No.	W	Material	Part no.				
					DN 25/50	DN 50/100	DN 80/150	DN 100/200	DN 150/300
750	Valve clack lever	1		St	10022263	10030245	10024633	10024633	10030453
752	Lock nut	1		St	13199	13200	13202	13202	13201
753	Valve clack, complete	1		Ms/NSt/St	10022262	10022312	10022407	10022407	10030452
754	O ring	1	W	KG	20236	20458	20313	20313	20338
766	Sealing cap	2		St	26175	26175	26175	26175	26175
767	Manual release, complete	1		Al/FSt/NSt	10022340	10022340	10022440	10022440	10022490
768	Thrust piece, spring-loaded	1		Ms/NSt	10022391	10022391	10022391	10022391	18355446
773	Cotter pin	1		St	15000	15000	15007	15007	15020
774	O ring	1		KG	20282	21334	21287	21287	100399
775	Pressure spring	1		FSt	10018394				
800	Headless pin (setscrew)	2		St		10030247			
800	Hex screw	2		St			10024648	10024648	10024648
801	Half length reserve taper grooved dowel pin	2		St		17200			
810	Probe valve	1			10005200	10005200	89100210	89100210	89100210
811	Screwed connection	1		St	31817	31817			
812	Connection pipe	1		St	30622	30622			
813	Union nut	3		St	30803	30803			
813	Union nut	1		St			30803	30803	30803
814	Cutting ring	3		St	30903	30903			
814	Cutting ring	1		St			30903	30903	30903
815	Screwed connection	1		St	31207	31207			

3.3.3 Spare parts drawing – accessories

Electromagnetic release when power connection is online

Electromagnetic release when power fails

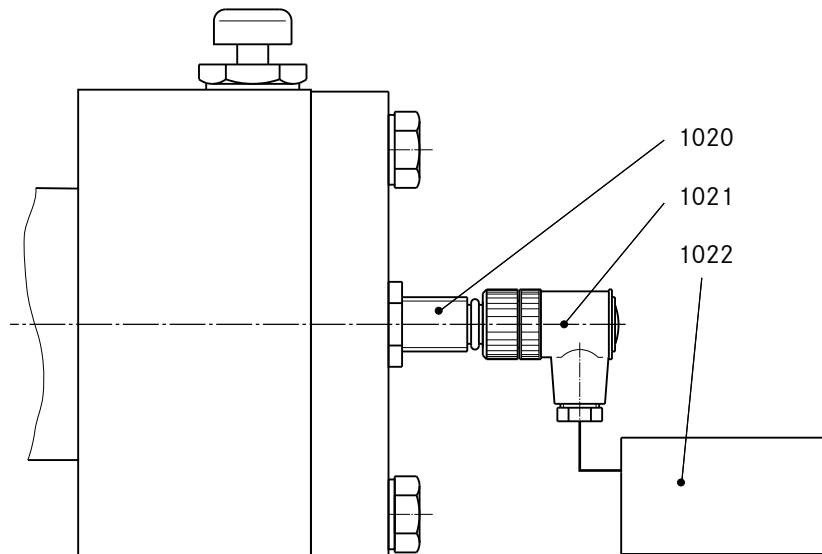
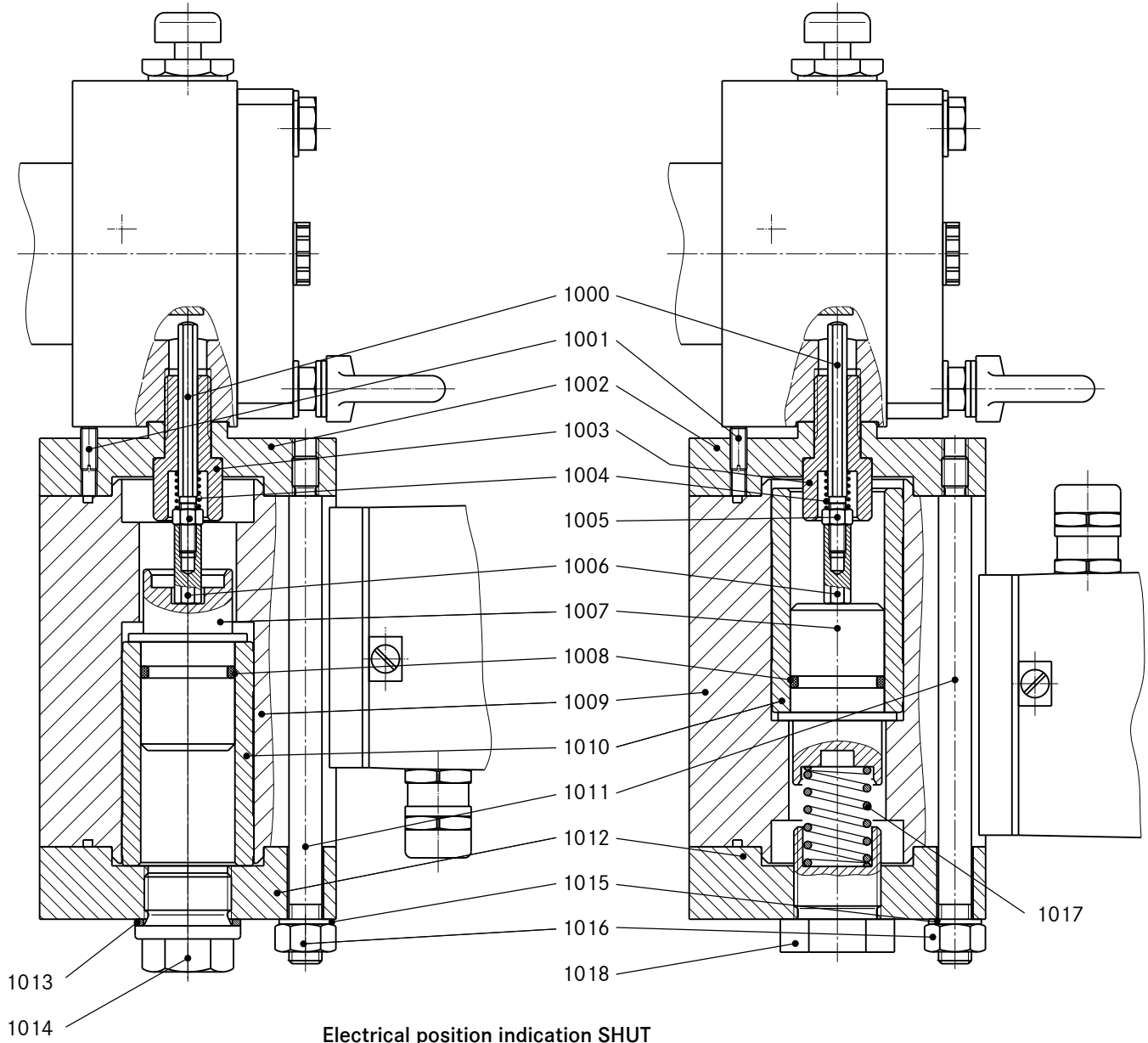

3.3.4 List of spare parts – accessories

Item No.	Denomination	No.	W	Material	Part no.
1000	Switching rod optionally for:				
1000	RMG 711 DN 25 and DN 50	1		NSt	10022568
1000	RMG 503 DN 25/50 and DN50/100	1		NSt	10022568
1000	RMG 530 DN 50/100	1		NSt	10022568
1000	RMG 711 DN 80 and DN 100	1		NSt	10022573
1000	RMG 503 and RMG 530 DN 80/150 and DN 100/200	1		NSt	10022573
1000	RMG 711 DN 1501			NSt	10022578
1000	RMG 503 DN 150/300	1		NSt	10022578
1001	Headless pin (setscrew)	1		St	8486
1002	Connecting flange	1		LM	10022582
1003	Guide screw	1		NSt	10001811
1004	Pressure spring	1		SF	18355195
1005	Hex nut	1		St	3020
1006	Adjusting nut	1		Ms	10001864
1007	Bush	1		LM	10022584
1008	O ring	1		KG	20327
1009	Magnet	1			100223
1010	Cutout arm	1			100224
1011	Threaded bolt	4		NSt	10022585
1012	Cap	1		LM	10022583
1013	Sealing ring	1		LM	18706
1014	Sealing cap	1		St	26523
1015	Lock washer	4		SF	14113
1016	Hex nut	4		St	5692
1017	Pressure spring	1		SF	28067
1018	Sealing cap	1		Ms	10022586
1020	Proximity switch	1			24160
1021	Cable box	1			24099
1022	Disconnection device, at option:				
1022	for 1 proximity switch (230V AC)	1			24402
1022	for 2 proximity switches (230V AC)	1			24403

4. Parts for maintenance purposes

Item No.	Denomination	Number	Part no.				
			DN 25/50	DN 50/100	DN 80/150	DN 100/200	DN 150/300
303	O ring	1	20508	20508	21184	21184	20541
306	Diaphragm	1	10011306	10011306	10011307	10011307	10023697
314	Plastic foam disc	1			10023593	10023633	10023689
319	Plastic foam ring	1			10023592	10023632	10023688
726	O ring	2	20227	20227	20235	20235	20336
727	O ring	2	21142	21142	20607	20607	20600
748	O ring	1	20247	20427	21361	21361	21108
754	O ring	1	20236	20458	20313	20313	20338