

# 60 Series Pilot Regulator

## Technical Bulletin



ITT Controls

## 60Series™ Pilot Regulator

The 60Series Pilot Regulator provides an accurate control pressure, improving the performance of all types of flexible-element main valves. The 60Series provides fast, accurate and stable pressure regulation. It is recommended for installations where there are large variations in inlet temperatures and pressures.

All 60Series Pilots use premium materials throughout.

- Pressure-vessel parts are forged brass conforming to ASTM B283 standards for maximum strength.
- Both low (60L) and high-pressure (60H) 60Series pilot diaphragms are molded Buna N with nylon-fabric reinforcement for high strength.
- Each 60Series diaphragm has a molded convolution in the working area to provide accurate pressure control and a long diaphragm life.
- 60Series internal regulating stems are stainless steel. A premium Buna N SoftSeat bonded to the stem assures a positive lockup and a long service life.

### Models

The 60Series Pilot is available in four (4) models:

- **(60L-PR)** Low Pressure (3-325 PSIG) – Pressure reducing
- **(60L-RV)** Low Pressure (3-325 PSIG) – Relief valve
- **(60H-PR)** High Pressure (250-900 PSIG) – Pressure reducing
- **(60H-RV)** High Pressure (250-900 PSIG) – Relief valve

### How To Order

Please contact your AMCO representative with:

- Model Number:  
(60L-PR), (60L-RV), (60H-PR), or (60H-RV)
- Position of Pilot Vent  
(Standard is vent over sense line.)
- Required Outlet Pressure (or Spring Range)
- Buna N or Viton diaphragm/seat disc
- For (optional) AFV and RFV Control Loop(s):
  - Specify Axial or Radial-Flow Valve
  - Composite Block, Inspirator Block or Bare Block
  - Specify Single-Stage Pressure Reduction, Worker, or Monitor



**60L – Low Pressure  
Pressure Reducing (PR)**

### Dimensions and Weights

| Model | Dimensions |        |        | Vent Size | Net Weight |
|-------|------------|--------|--------|-----------|------------|
|       | A          | B      | D      |           |            |
| 60L   | 3-1/16"    | 2-1/8" | 8-1/8" | 1/4 NPT   | 5.5 lb     |
| 60H   | 3-1/16"    | 2-1/8" | 8-1/8" | 1/4 NPT   | 5.7 lb     |

All connections are 1/4 NPT



## 60Series™ Pilot Regulator

### Pressure Reduction – PR (refer to diagram 60L-PR)

- Spring force from the main spring (1) is acting through the stem (2) and is holding the 60Series Pilot fully open.
- Note that the main spring force cannot damage the Soft SeatDisc (3), which is free to move downward against its retaining spring (6), preventing excess force.
- As outlet pressure under the diaphragm (4) builds, outlet pressure opposes the spring force that is holding the 60Series Pilot Regulator open. When there is a force balance, the Soft SeatDisc (3) moves upward to contact the orifice (5), shutting off flow and controlling pressure.

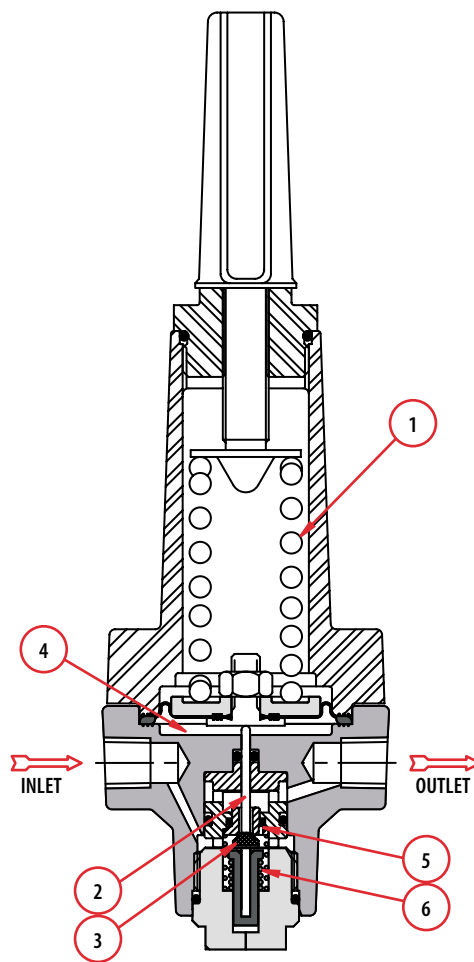

60Series™ Pilot Regulator Model 60L (PR) Pressure Reduction

### Relief Valve – RV (refer to diagram 60L-RV)

- Spring force from the main spring (1) is acting through the stem (2) and is holding the 60Series Pilot fully closed.
- Again, note that the main spring force cannot damage the Soft SeatDisc (3), which is free to move downward against its retaining spring (6), preventing excess force.
- As outlet pressure under the diaphragm (4) builds, outlet pressure opposes the spring force that is holding the 60Series Pilot Regulator closed. When there is a force balance, the Soft SeatDisc (3) moves upward away from the orifice (5), and flow commences. (back-pressure relief)

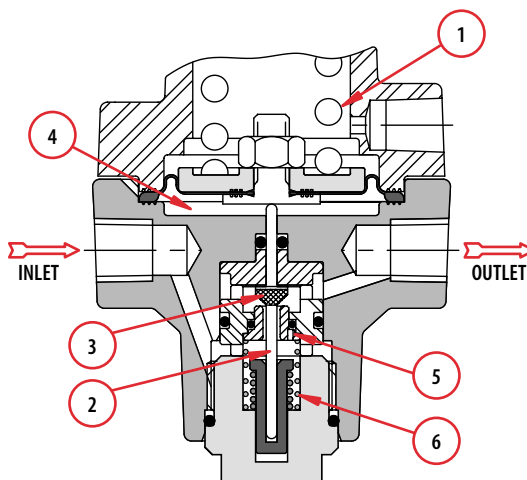

60Series™ Pilot Regulator Model 60L (RV) Relief Valve

### Pressure Ratings

**1480 PSIG** = Maximum allowable operating pressure (MAOP)

**2220 PSIG** = Shell-strength test pressure  
(all units production test)

**3 PSIG** = Minimum outlet pressure (60L models)

**325 PSIG** = Maximum outlet pressure (60L models)

**250 PSIG** = Minimum outlet pressure (60H models)

**900 PSIG** = Maximum outlet pressure (60H models)

**1350 PSIG** = Maximum outlet pressure  
(emergency without damage)



# 60Series™ Pilot Regulator

## Capacity in SCFH – 0.6 Specific Gravity Gas

CV = 13.4

FG = 1.29

Standard orifice size = .150"/.094"

| Inlet Pressure PSIG | Outlet Pressure PSIG |       |       |       |       |       |       |       |       |       |       |       |       |       |       |
|---------------------|----------------------|-------|-------|-------|-------|-------|-------|-------|-------|-------|-------|-------|-------|-------|-------|
|                     | 5                    | 10    | 25    | 50    | 60    | 100   | 200   | 300   | 40    | 500   | 600   | 700   | 800   | 900   |       |
| 10                  | 214                  |       |       |       |       |       |       |       |       |       |       |       |       |       |       |
| 25                  | 343                  | 343   |       |       |       |       |       |       |       |       |       |       |       |       |       |
| 50                  | 559                  | 559   | 559   |       |       |       |       |       |       |       |       |       |       |       |       |
| 60                  | 646                  | 646   | 646   | 440   |       |       |       |       |       |       |       |       |       |       |       |
| 80                  | 819                  | 819   | 819   | 762   | 668   |       |       |       |       |       |       |       |       |       |       |
| 100                 | 992                  | 992   | 992   | 992   | 945   |       |       |       |       |       |       |       |       |       |       |
| 200                 | 1856                 | 1856  | 1856  | 1856  | 1856  | 1856  |       |       |       |       |       |       |       |       |       |
| 300                 | 2720                 | 2720  | 2720  | 2720  | 2720  | 2720  | 2533  |       |       |       |       |       |       |       |       |
| 400                 | 3585                 | 3585  | 3585  | 3585  | 3585  | 3585  | 3585  | 3067  |       |       |       |       |       |       |       |
| 500                 | 4449                 | 4449  | 4449  | 4449  | 4449  | 4449  | 4449  | 4337  | 3520  |       |       |       |       |       |       |
| 600                 | 5313                 | 6313  | 6313  | 6313  | 6313  | 6313  | 6313  | 6313  | 6313  | 4978  | 3922  |       |       |       |       |
| 700                 | 6177                 | 6177  | 6177  | 6177  | 6177  | 6177  | 6177  | 6177  | 6177  | 6097  | 5546  | 4286  |       |       |       |
| 800                 | 7042                 | 7042  | 7042  | 7042  | 7042  | 7042  | 7042  | 7042  | 7042  | 7042  | 6793  | 6061  | 4621  |       |       |
| 900                 | 7906                 | 1906  | 7906  | 7906  | 7906  | 7906  | 7906  | 7906  | 7906  | 7906  | 7844  | 7423  | 6536  | 4934  |       |
| 1000                | 8770                 | 8770  | 8770  | 8770  | 8770  | 8770  | 8770  | 8770  | 8770  | 8770  | 8770  | 8572  | 8004  | 6978  | 5228  |
| 1200                | 10499                | 10499 | 10499 | 10499 | 10499 | 10499 | 10499 | 10499 | 10499 | 10499 | 10499 | 10499 | 10334 | 9868  | 9055  |
| 1480                | 12919                | 12919 | 12919 | 12919 | 12919 | 12919 | 12919 | 12919 | 12919 | 12919 | 12919 | 12919 | 12919 | 12866 | 12591 |

□ Sub-Critical Flow

■ Critical Flow

### Capacity Formulas

- Sub-Critical Flow Formula

Use when  $(P_2+14.73) > .53 * (P_1+14.73)$ 

$$Q = C * \sqrt{(P_2+14.73) * h} * F_g$$

- Critical Flow Formula

$$Q = 0.5C * (P_1+14.73) * F_g$$

Q = SCFH (cubic feet per hour @ 14.73PSIA and 60°F)

P1 = Inlet Pressure (PSIG)

P2 = Outlet Pressure (PSIG)

h = Differential pressure (P1-P2)

C = Orifice constant (13.4 for all 60Series Pilots)

Fg = Specific gravity factor  $\sqrt{\frac{1}{S.G.}}$ 

### Examples

- 60Series Pilot operating on .6 S.G. natural gas

Inlet pressure (P1) = 80 PSIG

Outlet Pressure (P2) = 60 PSIG

**Find:** full capacity (Q) in SCFH

Test for sub-critical flow:

 $(P_2+14.73) > .53 * (P_1+14.73)$  $(60+14.73) > .53 * (80+14.73)$  $(74.73 > 50.2) \rightarrow \text{TRUE}$ **Therefore: Flow is sub critical**

Use sub-critical flow formula:

 $Q = C * \sqrt{(P_2+14.73) * h} * F_g$  $Q = 13.4 * \sqrt{(60+14.73) * 20} * 1.29$ **Q = 668 SCFH ← ANSWER**

- 60Series Pilot operating on .6 S.G. natural gas

Inlet pressure (P1) = 300 PSIG

Outlet Pressure (P2) = 60 PSIG

**Find:** full capacity (Q) in SCFH

Test for sub-critical flow:

 $(P_2+14.73) > .53 * (P_1+14.73)$  $(60+14.73) > .53 * (300+14.73)$  $(74.73 > 166.8) \rightarrow \text{FALSE}$ **Therefore: Flow is critical**

Use critical-flow formula:

 $Q = 0.5 C * (P_1+14.73) * F_g$  $Q = 6.7 * (300+14.73) * 1.29$ **Q = 2720 SCFH ← ANSWER**

## 60Series™ Pilot Regulator with optional Jordan® Electronic Controller

### Available OEM with Jordan® Electronic Controllers

- Factory assembled and tested to your specifications
- Integral top mount retains pilot serviceability
- Allows remote pressure adjustment from gas control

### How To Order

Please contact your AMCO representative with 60Series Pilot ordering information and:

- Jordan Model Number:  
(SM1020 recommended)
- Gearbox Option (Required)
- Mounting (60Series Pilot/Full Assembly and Test)
- Voltage Input 120/240 VAC – or – 12/36 VDC
- Signal Options
  - None
  - 3 wire, 120/240 VAC incremental control
  - 2 wire, DC incremental control

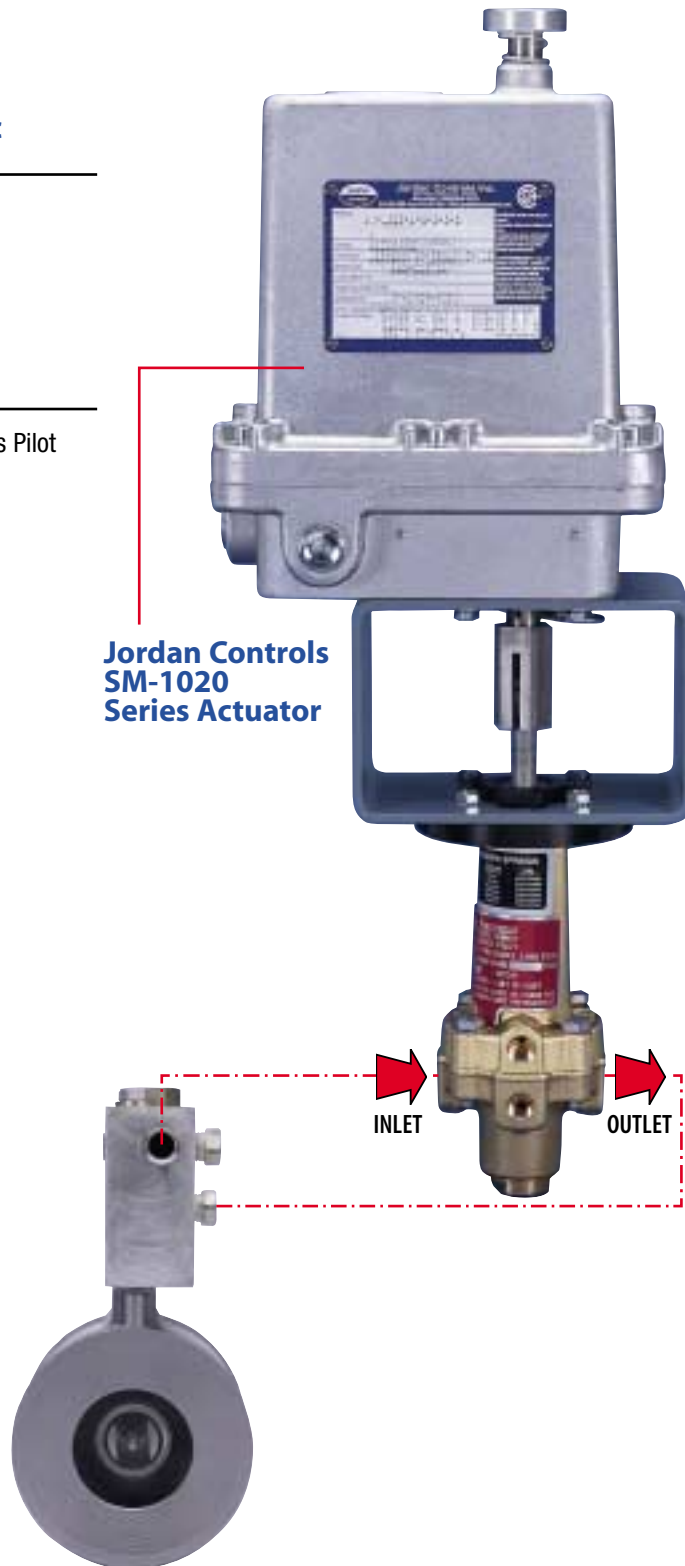

Jordan Controls  
SM-1020  
Series Actuator