

# Hydramotor<sup>®</sup> Actuators

## H30/H35 Hydramotor<sup>®</sup> Fail-Safe, Electrohydraulic Linear Actuators

### INTRODUCTION

H30/H35 Hydramotors are electrohydraulic, linear actuators. They feature a completely self-contained, sealed, hydraulic motor/pump power unit coupled to a hydraulic cylinder containing both piston/shaft assembly and return spring.

The positive, firm positioning actuators are ideal for providing efficient and precise linear control of valves, dampers, louvers, and a wide variety of other equipment requiring an operating thrust of up to 2,600 lbs (1,179 kg) and an output shaft extension of up to 2 5/8 in (66.8 mm).

### PRINCIPLE OF OPERATION

The H30/H35 Series actuators are the result of over 50 years of experience in designing, testing, manufacturing, and servicing electrohydraulically powered actuators.

Units are available in both push or pull power stroke, with a choice of either spring-return or lock-in-last position upon loss of power.

The spring-return version offers the user "fail-safe" operation. The internal cylinder spring returns the actuator shaft to its deenergized position upon power interruption.

The lock-in-last position version allows the user to independently control the return of the actuator shaft to the deenergized position after loss of supply power.

Field experience has proven the H30/H35 Series to be extremely reliable. Quality design, construction, and materials ensure minimum service requirements and a prolonged service life. Gears have been eliminated in favor of a modular design using fewer moving internal components and industry proven heat-resistant seals which are immersed in oil for continuous lubrication.

An enamel-finished, die-cast aluminum exterior housing and corrosion-resistant steel output shaft components allow H30/H35 Hydramotors to perform in the most demanding, rugged, and hostile industrial environments.

### FEATURES

- Push or Pull Hydraulic Ram Power
- Gross Shaft Force Output from 800 to 2,600 lbs.
- Fail-Safe Operation Spring-Return, or Lock-in-Last Position
- Completely Self-Contained, Sealed Unit
- Travel or Force Limit Control
- Application Versatility
- Wide Array of Mountings and Options

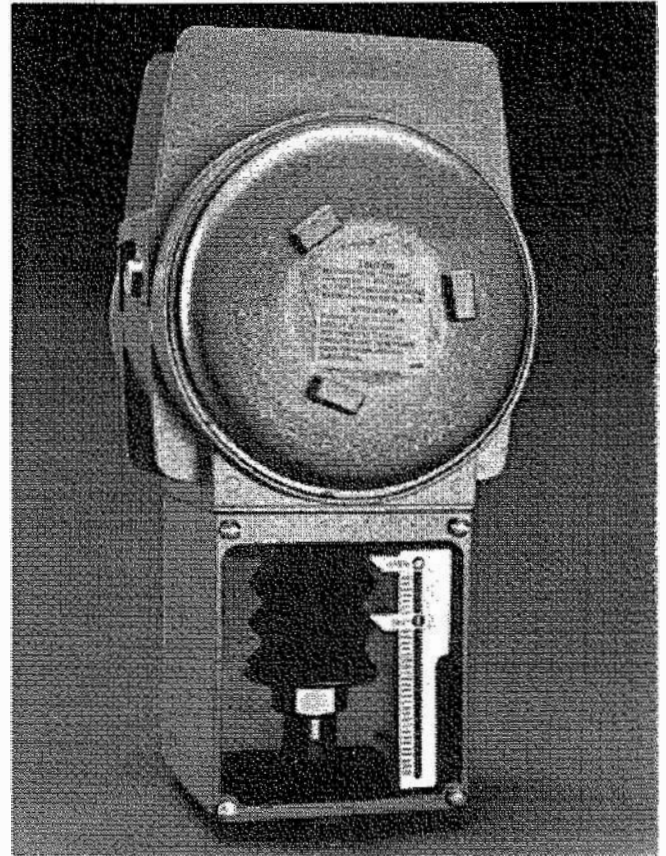

H30/H35 Hydramotor<sup>®</sup> (Explosion-Proof Housing)

### HOW TO ORDER

To select the H30 Series actuator for your application, the operating conditions of the Process Control Device (PCD) must first be identified:

- Maximum stem force at all significant stem positions
- Available power supply
- Control mode – travel limit or force limit
- Operating mode – push or pull when energized
- Power failure mode – spring-return or lock-in-last position
- Valve interface dimensions
- Operating environment – indoors, outdoors, or hazardous environment
- Feedback instrumentation to be used

Output force of the selected actuator should exceed the PCD stem force requirements at the end of the stroke in both hydraulic power direction and spring return directions.

*Hydraulic Force and Spring Force Charts for the H10 through H35 Hydramotor Actuators* is available from ASCO General Controls to aid in selecting the appropriate actuator for your application.

# Hydramotor® Actuators

## ACTUATOR SPECIFICATIONS

### OPERATING MODES

- H30** Two-Position, Spring-Return, Pull-Type. Shaft retracts on application of power; spring extends on loss of power.
- H31** Two-Position, Spring-Return, Push-Type. Shaft extends on application of power; spring retracts on loss of power.
- H34** Two-Position, Lock-in-Last Position, Pull-Type. Shaft retracts on application of power; lock-in-last position on power failure, spring extends when relief valve is energized. (Normally-closed relief valve wired independently of motor circuit.)
- H35** Two-Position, Lock-in-Last Position, Push-Type. Shaft extends on application of power; lock-in-last position on power failure, spring retracts when relief valve is energized. (Normally-closed relief valve wired independently of motor circuit.)

**Other Actuator Ratings** See the AH90 Series Technical Data Sheets for larger actuators having strokes up to 4" (10.2 cm) and gross stem forces of up to 4,000 lbs (1,818 kg).

### POWER INPUT

- Voltages** Available single-phase voltages include: 120 V 50/60 Hz; 240 V 50/60 Hz. Consult factory for other voltages.
- Current** 168 VA

### ELECTRIC MOTOR

- Type** 2-Pole, Single-Phase (Shaded Pole)
- Wiring** Class B 105°C (220°F)
- Duty Cycle** 80%

### HYDRAULIC SYSTEM

- Force Output** 800 lb, 1,400 lb, 2,600 lb (maximum)
- Relief Valve** Normally-Open – *Spring-Return*  
Normally-Closed – *Lock-In-Last Position*
- Hydraulic Oil** MIL-H-5606
- Oil Capacity** four pints
- Pump** Single piston, positive displacement with integral check valve
- Filter Capacity** 10 times pump capacity
- Seals** Nitrile – 70 shore durometer

### VALVE STEM NUT

A valve stem nut is normally required when installing an H10/H25 Series actuator on a linear-motion valve. Contact your ASCO General Controls distributor, and specify actuator catalog number and valve stem dimensions.

### ENCLOSURE (CSA Listed)

- Standard** Type 1 – Meets general purpose indoor requirements
- Optional** Type 4 – Meets watertight requirements  
Type 4 & 7 – Meets watertight and hazardous location requirements; Class I, Division 1, Groups C & D

### STORAGE ENVIRONMENT

**Temperature Range** -65°F (-54°C) to +150°F (+66°C)

### OPERATING ENVIRONMENT

- Temperature** -40°F (-40°C) to +150°F (+66°C)
- Atmosphere** Industrial applications (including hazardous)

**Humidity** 0-100% RH

**Mounting** Yoke Bottom Mount – Locknut or 4 bolts

**Sub-Zero Start-up** The actuator operates at sub-zero ambient temperature, but stroke time will increase

### MATERIALS

- Electrical Housing** Type 1, 4 and 7: Cast Aluminum - AA 356-T6 (UNS A13560)
- Cylinder Housing** Cast Aluminum - AA 356-T6 (UNS A13560)
- Power Unit** Sheet Steel - AISI 1010 (UNS G10100)
- Output Shaft** Stainless Steel - AISI 430F (UNS S31600)
- Yoke** Cast Aluminum - AA 356-T6 (UNS A13560)  
Cast Iron - ASTM (A48) (UNS F12101)
- Standard Finish** Hammertone Blue Enamel

### NOTES

- <sup>a</sup> Operating Mode corresponds to the Power Unit
- <sup>b</sup> Timing for Full Stroke (2 5/8") (66.8 mm). Timing is proportional to stroke length.
- <sup>c</sup> Not applicable for force (pressure) limit type.
- <sup>d</sup> **Example: H34 A1 2 2 0 B10 C1 D5 E6 F13 G1.**

Pull-type, Lock-in-last position, 1,400 lb force output, adjustable 65 to 120 second power stroke, 3 second (maximum) return stroke, 120 V 50/60 Hz, travel limit switch

Extended cast iron yoke, Type 4 and 7 enclosure for hazardous environment, high-temperature wiring/gasket, 50% external spring, one FM proof-of-closure switch and one adjustable auxiliary switch, relief valve voltage 12 Vdc.

Some combinations of options may not be available. Consult factory to verify your selection.



# Hydramotor® Actuators

**OPERATING MODE** H30 Pull-Type, Spring-Return on Power Failure  
 H31 Push-Type, Spring-Return on Power Failure

H34<sup>a</sup> Pull-Type, Lock-in-Last Position  
 H35<sup>a</sup> Push-Type, Lock-in-Last Position

**POWER UNIT**

	Force	Power Stroke <sup>b</sup>	Return Stroke <sup>b</sup>
A11	2600 lbs.	120 sec.	8-15 sec.
A12	1400 lbs.	65 sec.	8-15 sec.
A13	800 lbs.	40 sec.	2 sec.
A15	2600 lbs.	120 sec.	Adj. 6-120 sec.
A16	1400 lbs.	65 sec.	Adj. 6-120 sec.
A17	2600 lbs.	120 sec.	3 sec.
A18	800 lbs.	Adj. 40-56 sec.	2 sec.
A19	1400 lbs.	65 sec.	3 sec.
A26	800 lbs.	Adj. 40-120 sec.	Adj. 6-120 sec.

	Force	Power Stroke <sup>b</sup>	Return Stroke <sup>b</sup>
A23 <sup>a</sup>	800 lbs.	Adj. 40-56 sec.	Adj. 6-120 sec.
A24 <sup>a</sup>	800 lbs.	Adj. 40-56 sec.	3 sec. max.
A25 <sup>a</sup>	800 lbs.	40 sec.	3 sec. max.
A27 <sup>a</sup>	800 lbs.	Adj. 40-56 sec.	Adj. 6-120 sec.
A28 <sup>a</sup>	800 lbs.	Adj. 40-56 sec.	3 sec. max.
A29 <sup>a</sup>	2600 lbs.	Adj. 120-202 sec.	3 sec. max.
A40 <sup>a</sup>	2600 lbs.	Adj. 120-202 sec.	Adj. 6-120 sec.
A41 <sup>a</sup>	2600 lbs.	Adj. 4-120 sec.	Adj. 6-120 sec.
A42 <sup>a</sup>	2600 lbs.	Adj. 120-240 sec.	Adj. 6-120 sec.
A44 <sup>a</sup>	1400 lbs.	Adj. 65-120 sec.	3 sec. max.
A48 <sup>a</sup>	1400 lbs.	65 sec.	2 sec. max.
A52 <sup>a</sup>	2600 lbs.	Adj. 120-240 sec.	3 sec. max.
A54 <sup>a</sup>	800 lbs.	40 sec.	5 sec. max.

**SUPPLY VOLTAGE** 2 120 VAC, 50/60 Hz  
 (168VA) 4 240 VAC, 50/60 Hz

**CONTROL MODE** 0 Travel Limit (Available on H30 and H34 only)  
 1 Force Limit (Available on H30, H31, H34, and H35)

**YOKE AND STEM**

	Length	Material	Yoke Mount Dia. (in.)	Max. Stem Dia. (in.)
X	No Yoke		----- consult factory -----	
B10	Standard	Aluminum	2 1/8 Dia.	7/16
B11	Standard	Cast Iron	2 13/16 Dia.	5/8
B13	Semi-Extended	Cast Iron	2 1/8 Dia.	7/16 (use no spring or E1 only)
B15	Extended	Cast Iron	2 1/8 Dia.	7/16
B16	Extended	Cast Iron	2 13/16 Dia.	5/8
B17	Extended	Cast Iron	3 9/16 Dia.	5/8
B18	Extended	Cast Iron	2 1/8 Dia.	7/16
B19	Extended	Cast Iron	3 9/16 Dia.	1 1/4
B20	Standard	Aluminum	3 1/8, 4-bolt	7/16
B21	Extended	Cast Iron	3 1/8, 4-bolt	7/16
B22	Extended	Cast Iron	2 1/8 Dia.	5/8

**ENCLOSURE** NO SYMBOL Type 1 Standard General Purpose Enclosure  
 C1 Type 4 (Dust-Proof, Drip-Proof, Weatherproof, Raintight)  
 C2 Type 4 and Type 7 (Explosion-proof)  
 C3 Type 4 and Type 7 (Explosion-proof with Breather and Drain)

**SPECIAL** D1 Three-wire (Series C)  
 D5 High Temperature/Actuator Interface Gasket

**RETURN SPRING** (Available only on H30 and H34 with extended yoke)

NO SYMBOL Standard 10% Internal Spring  
 E1 25% External Spring for 2,600 lb. Power Unit (Use on B13 only)  
 E5 50% External Spring for 2,600 lb. Power Unit  
 E6 50% External Spring for 1,400 lb. Power Unit  
 E7 50% External Spring for 800 lb. Power Unit  
 E9 75% External Spring for 2,600 lb. Power Unit  
 E10 100% External Spring for 2,600 lb. Power Unit  
 E11 100% External Spring for 1,400 lb. Power Unit  
 E12 100% External Spring for 800 lb. Power Unit

**MISCELLANEOUS OPTIONS**

F1 Standard – Integral Auxiliary Switch (end of Power Stroke)<sup>c</sup>  
 F3 Dust Shields on Yoke  
 F8 Dust Shields with FM Safety Wire  
 F13 3 Auxiliary Switches, Yoke-Mounted  
 F16 6 Auxiliary Switches, Yoke-Mounted  
 F17 6 Auxiliary Switches, Actuator-Mounted  
 F20 M.O.D. (pull-type/extended yoke only)  
 F26 One FM Proof-of-Closure Switch  
 F27 One FM Proof-of-Closure Switch, One Adjustable Switch  
 F28 Two FM Proof-of-Closure Switches, One Adjustable Switch  
 F34 Epoxy Exterior Finish

**RELIEF VALVE VOLTAGE** (H34 and H35 only)

NO SYMBOL Same Voltage As Motor  
 G1 125 VDC G2 48 VDC G3 12 VDC G4 24 VDC  
 G5 110 VDC G6 220 VDC G7 250 VDC (H34 & H35 only)

H34 A44 2 0 B15 C2 D5 E6 F27 G3 (Example)<sup>d</sup>

# Hydramotor® Actuators

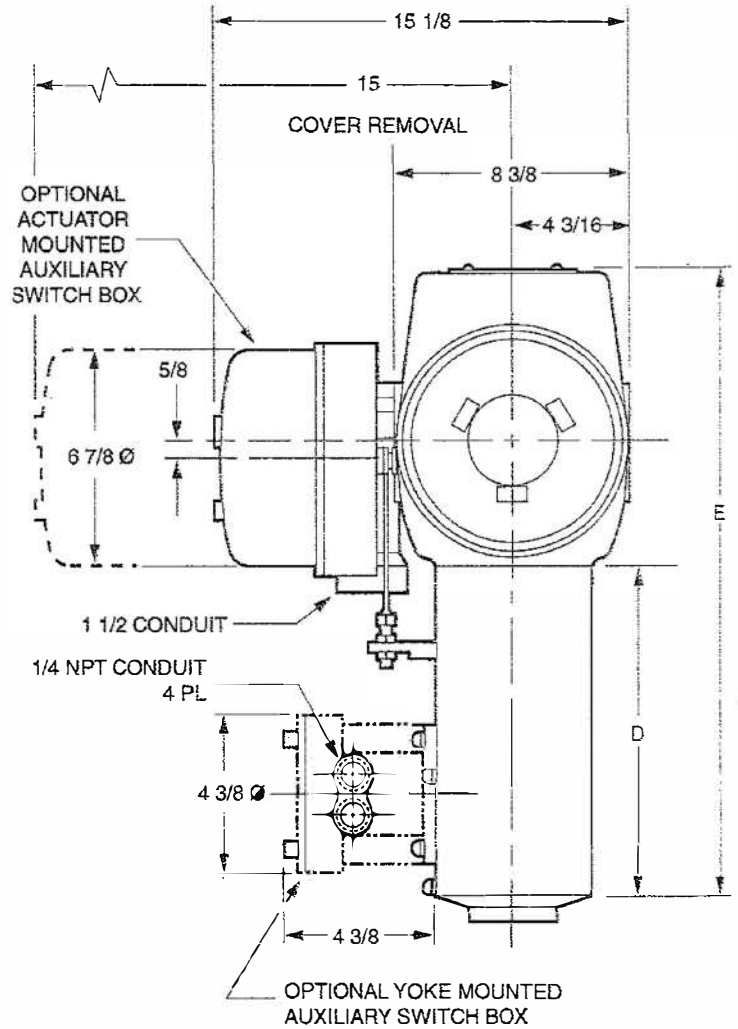
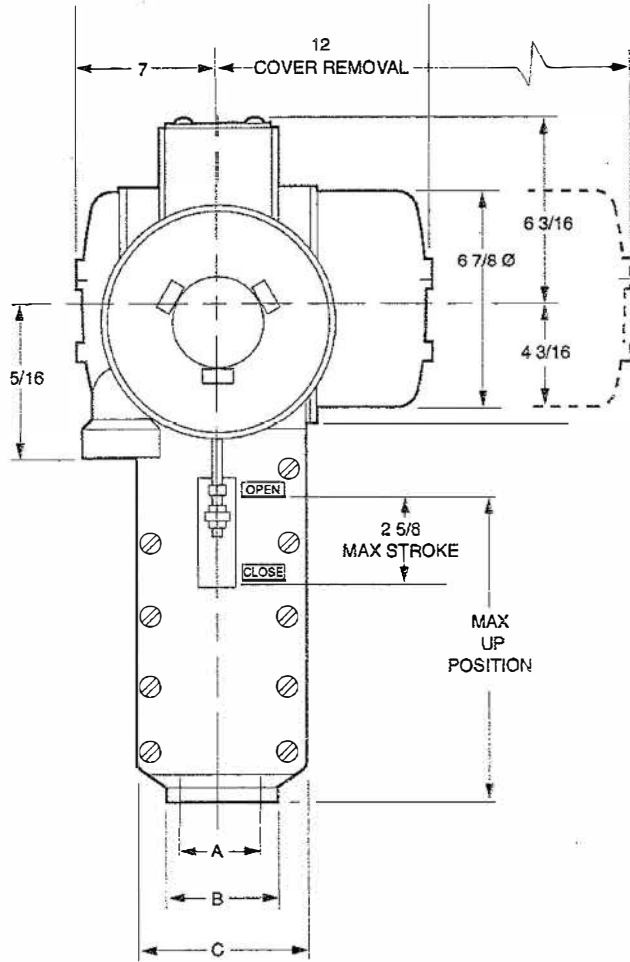

## H30/35 Dimensions

YOKE		DIMENSIONS (inch)					BOLT CIRCLE	HOLE (4)	UP POSITION
OPTION	MAT'L	A	B	C	D	E			
B10	AL	2 1/8	3 13/16	5 13/16	6 3/4	17 1/8		4 1/4	
B11	CI	2 13/16	3 13/16	5 13/16	8	18 3/8		5 1/2	
B13	CI	2 1/8	2 3/4	5 7/8	11 1/4	21 5/8		4 1/4	
B15	CI	2 1/8	2 3/4	7 1/8	15 7/8	26 1/4		4 1/4	
B16	CI	2 13/16	3 3/4	7 1/8	15 7/8	26 1/4		5 1/2	
B17	CI	3 9/16	4 5/8	7 1/8	15 7/8	26 1/4		7	
B18	CI	3 9/16	4 5/8	7 1/8	15 7/8	26 1/4		7	
B19	CI	3 9/16	4 5/8	7 1/8	15 7/8	26 1/4		7	
B20	AL	2 1/2	3 3/4	5 3/4	6 3/4	17 1/8	3 1/8	11/32	4 1/4
B21	CI	2 1/2	3 3/4	7 1/8	15 7/8	26 1/4	3 1/8	11/32	4 1/4
B22	C1	2 1/8	3 3/4	2 1/8	15 7/8	26 1/4			